

Motorschutzbügel MOTO GUZZI V7 Classic

Artikel-Nr.:
501.540 00 02 chrom

Seitenkoffer
Topcases
Gepäckträger
Lock it System
Softbags
Aluminiumkoffer
Lederkoffer
Schutzbügel
Hauptständer
Chopper-Parts
Quad-Parts
Accessoires



Montage

Der Bausatz umfaßt die folgenden Teile:

Stück	Bestellnr.	Bezeichnung
1	706.508HB	Motorschutzbügel, links
1	706.509HB	Motorschutzbügel, rechts
1	706.510HB	Haltebügel
4	151.051	Edelstahlschellen ø29
2	150.763	Inbusschraube M 6 x 20
2	150.767	Inbusschraube M 6 x 40
6	150.938	Linsenkopfschraube M 8 x 20
4	150.809	U-Scheibe ø6,4
10	150.810	U-Scheibe ø8,4
4	150.800	Selbstsichernde Mutter M8
1	151.190	Schutzfolie 20 x 15 cm

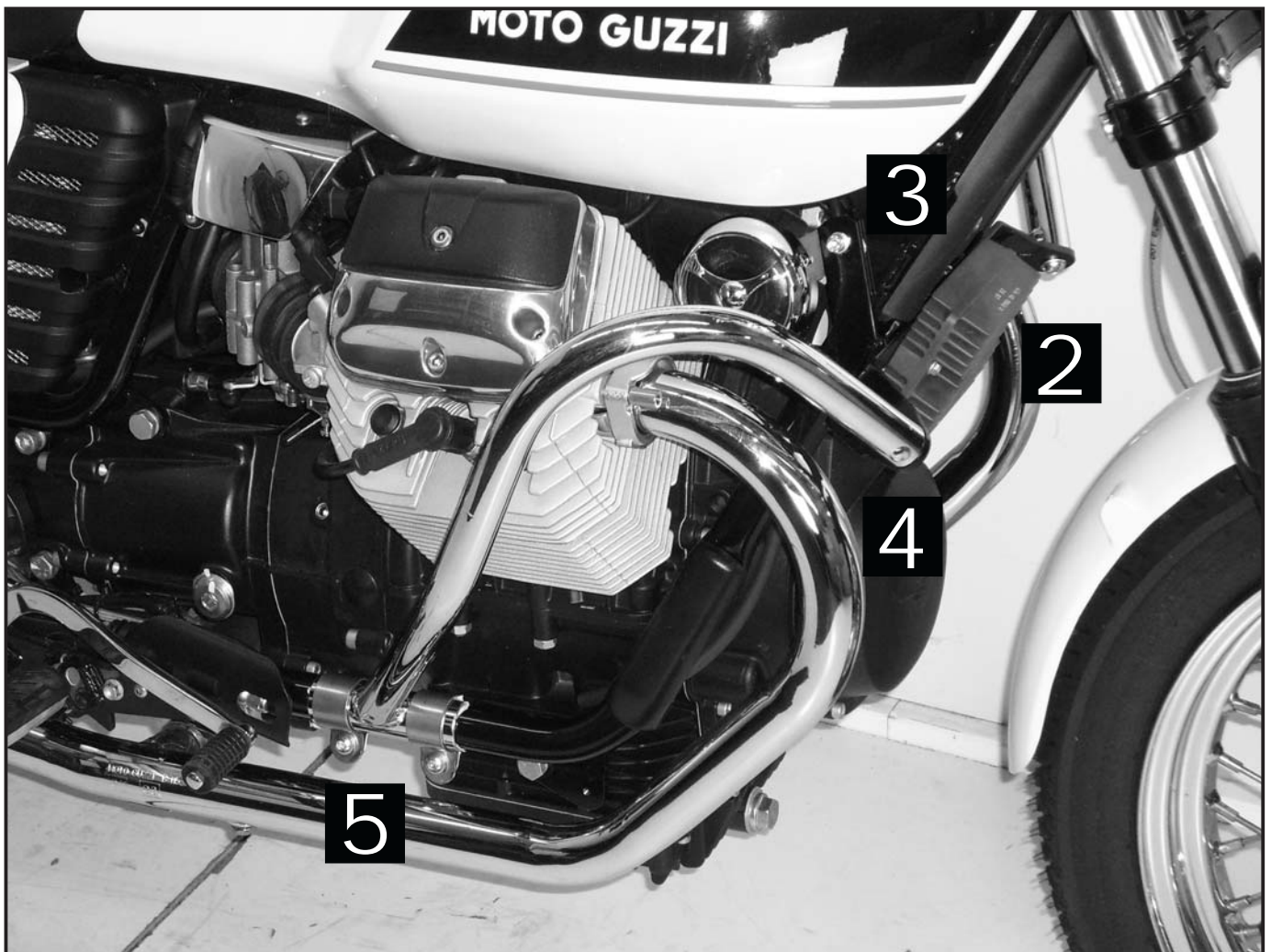

Motorschutzbügel
MOTO GUZZI V7 Classic

Artikel-Nr.:
501.540 00 02 chrom

Seitenkoffer
Topcases
Gepäckträger
Lock it System
Softbags
Aluminiumkoffer
Lederkoffer
Schutzbügel
Hauptständer
Chopper-Parts
Quad-Parts
Accessoires



Montage

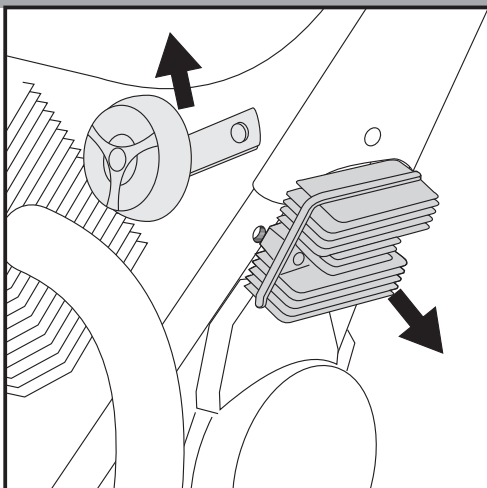

1

Vorbereitung:
Gleichrichter und Hupen links und rechts demontieren.
Originalschrauben entfallen.

Tipp:
Schrauben sie alle Teile an und lassen sie die zugänglichen Schrauben etwas locker. Nachdem alles montiert ist, werden alle Schrauben auf das entsprechende Anzugsmoment angezogen. Dadurch wird sichergestellt, dass das Produkt spannungsfrei angebaut ist. Damit ist eine lange Lebensdauer sichergestellt !

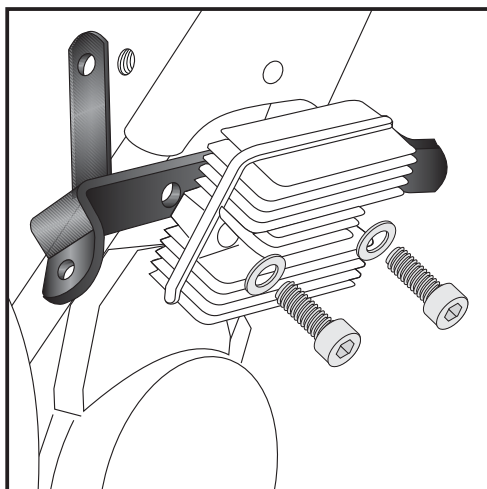

2

Montage des Haltebügels:
Der Haltebügel wird über den freien Bohrungen der Gleichrichterbefestigung platziert und mit diesem zusammen wieder verschraubt. Hierzu die Inbusschrauben M6 x 40 mit U-Scheiben $\varnothing 6,4$ verwenden.

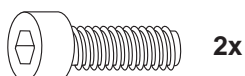

2x

2x

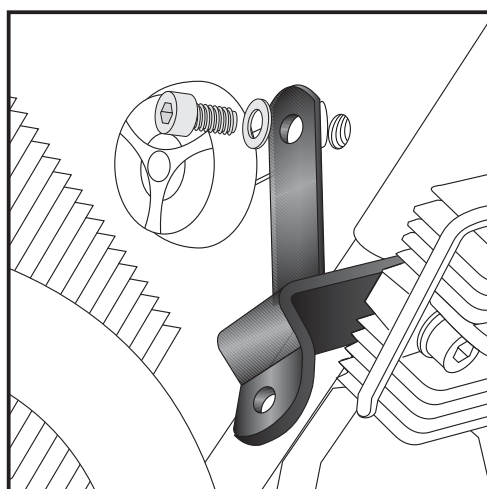

3

Befestigung der Hupen links und rechts:
An der Lasche des Haltebügels.
Zur Befestigung die Inbusschrauben M 6 x 20 mit U-Scheibe $\varnothing 6,4$ verwenden.

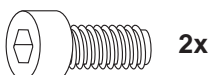

2x

2x



Motorschutzbügel
MOTO GUZZI V7 Classic

Artikel-Nr.:
501.540 00 02 chrom

Seitenkoffer
Topcases
Gepäckträger
Lock it System
Softbags
Aluminiumkoffer
Lederkoffer
Schutzbügel
Hauptständer
Chopper-Parts
Quad-Parts
Accessoires



Montage

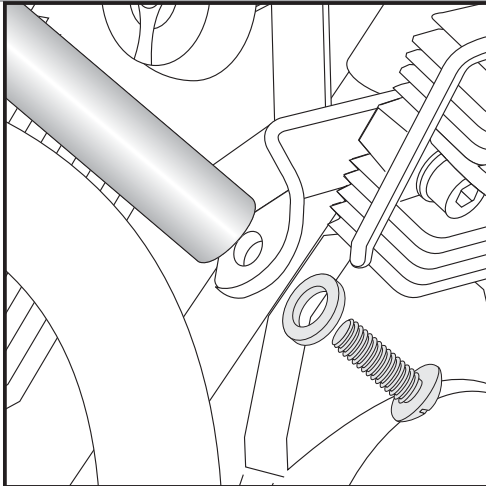

4

Montage der Motorschutzbügel links und rechts oben:
Am zuvor montierten Haltebügel.
Hierzu die Linsenkopfschrauben M8 x 20 mit U-Scheiben $\varnothing 8,4$ verwenden.

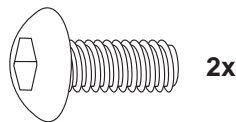

2x

2x

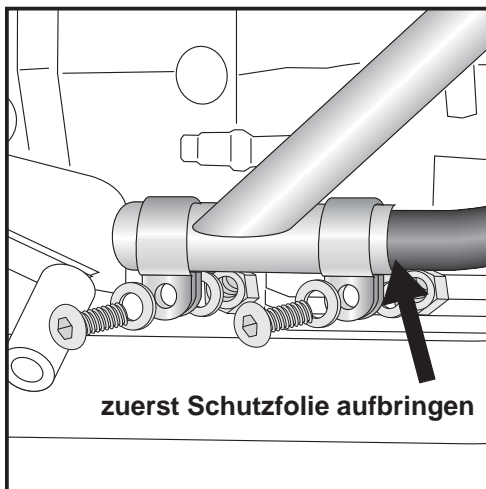
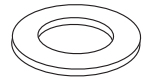

5

Montage der Motorschutzbügel links und rechts unten:
Die Kontaktfläche des Motorschutzbügels am Rahmen wird zuerst mit einer Schutzfolie beklebt. Dazu ein passendes Stück aus der beiliegenden Folie ausschneiden und an der Stelle aufbringen, wo der Motorschutzbügel am Rahmen aufliegt.

Der Haltebügel wird am Rahmen plziert und pro Seite mit zwei Edelstahlschellen $\varnothing 29$ befestigt.
Hierzu die Linsenkopfschrauben M8 x 20 mit U-Scheiben $\varnothing 8,4$ und selbstsichernden Muttern verwenden.

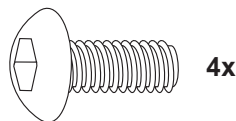

4x

8x



4x



Anzugsmomente des Motorradherstellers beachten!
Nach der Montage alle Verschraubungen auf festen Sitz kontrollieren!
Bitte beachten Sie unsere beigefügten Serviceinformationen.

Als weiteres Zubehör lieferbar:

Kofferträger 650.540 00 02 chrom
Gepäckbrücke 650.540 01 02 chrom



Hepco & Becker GmbH
An der Steinmauer 6

D-66955 Pirmasens

Tel.: 06331 - 1453 - 100

Fax: 06331 - 1453 - 120

eMail: vertrieb@hepco-becker.de

www.hepco-becker.de

Engine guard
MOTO GUZZI V7 Classic

Item - No.:
501.540 00 02 chrome

Side cases
Top cases
luggage frames
Lock it system
Softbags
Aluminium luggage
Leather luggage
Protection bars
Center stands
Chopper parts
Quad parts
Accessories



Assembling instructions

The kit includes the following parts:

Quant	item no.	description
1	706.508HB	Engine guard, left
1	706.509HB	Engine guard, right
1	706.510HB	adapter bow
4	151.051	frame adapter $\varnothing 29$
2	150.763	allen screw M 6 x 20
2	150.767	allen screw M 6 x 40
6	150.938	filister head screw M 8 x 20
4	150.809	washer $\varnothing 6,4$
10	150.810	washer $\varnothing 8,4$
4	150.800	self-lock nut M8
1	151.190	protection film 20 x 15 cm

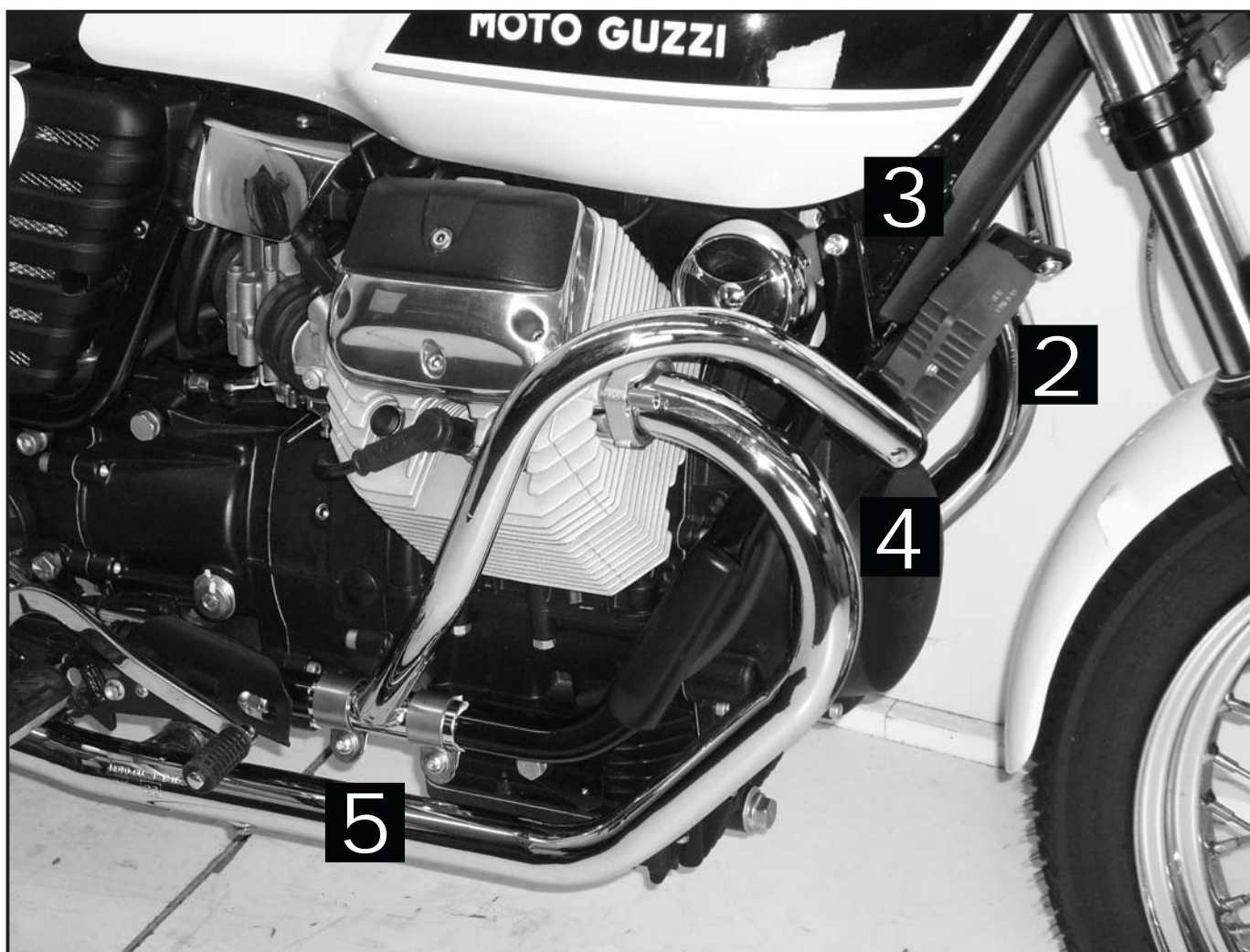

Engine guard
MOTO GUZZI V7 Classic

Item - No.:
501.540 00 02 chrome

- Side cases
- Top cases
- luggage frames
- Lock it system
- Softbags
- Aluminium luggage
- Leather luggage
- Protection bars
- Center stands
- Chopper parts
- Quad parts
- Accessories



Assembling instructions

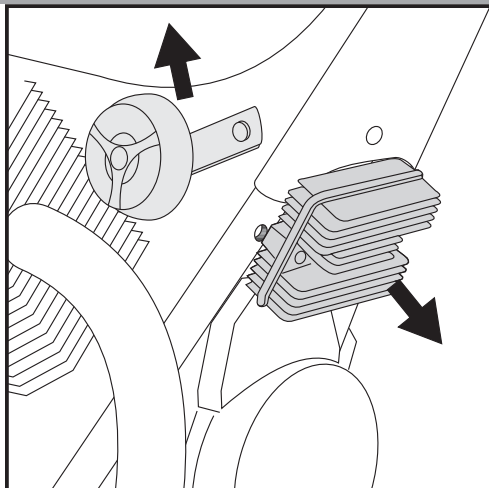

1

Preparing:
Dismantle signal-horns and the rectifier.
Original screws are not needed any more.

Tip:

Fit all parts and screw on not too strong.
After mounting all parts, the screws should be tightened to the torque specified.
This guarantees, that the kit is mounted without tension.

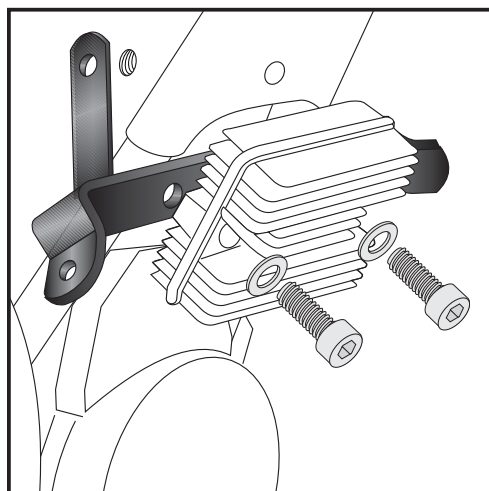

2

Fastening of the adapter bow:
at the free borings of the rectifier.
Mount the bow together with the rectifier with allen screws M6 x 40 and washers $\varnothing 6,4$.

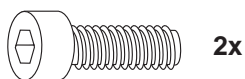

2x

2x

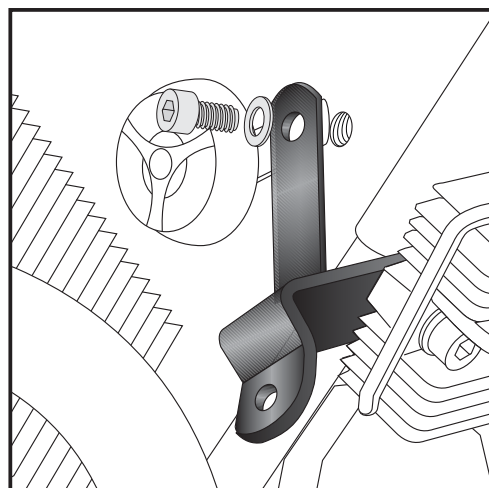

3

Fastening of the signal-horns left + right:
at the shackles of the adapter bow.
Use allen screws M6 x 20 and washers $\varnothing 6,4$.

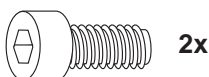

2x

2x



Engine guard
MOTO GUZZI V7 Classic

Item - No.:
501.540 00 02 chrome

- Side cases
- Top cases
- luggage frames
- Lock it system
- Softbags
- Aluminium luggage
- Leather luggage
- Protection bars
- Center stands
- Chopper parts
- Quad parts
- Accessories



Assembling instructions

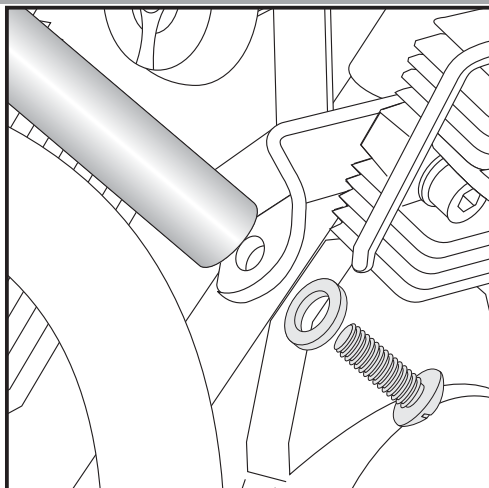

4

Fastening of the engine guard left + right top:
at the adapter bow.
Use filister head screws M8 x 20 and washers $\varnothing 8,4$.

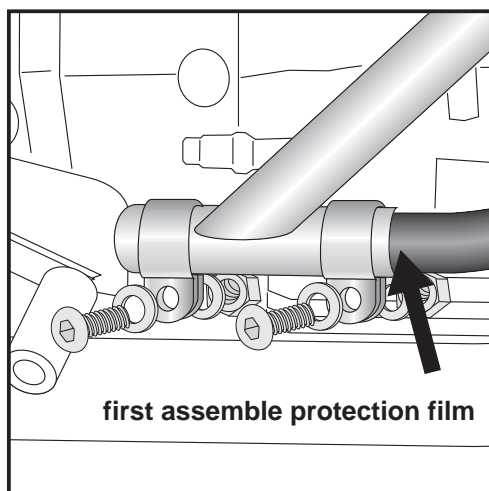
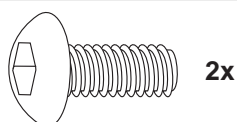

5

Fastening of the engine guard left + right bottom:
at the frame with the frame adapters $\varnothing 29$.
First assemble protection film at the position where the engine guard touches the frame tube.
To fix the engine guard, use filister head screws M8 x 20, washers $\varnothing 8,4$ and self-lock nuts M8.

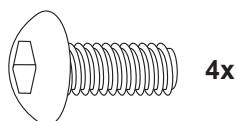

Control all screw connections after the assembling for tightness!
Please notice our enclosed service information.

Also available:

Side carrier 650.540 00 02 chrome
Rear carrier 650.540 01 02 chrome



Hepco & Becker GmbH
An der Steinmauer 6
D-66955 Pirmasens
Germany

Tel.: +49 6331 - 1453 - 100
Fax: +49 6331 - 1453 - 120
eMail: vertrieb@hepco-becker.de
www.hepco-becker.de